

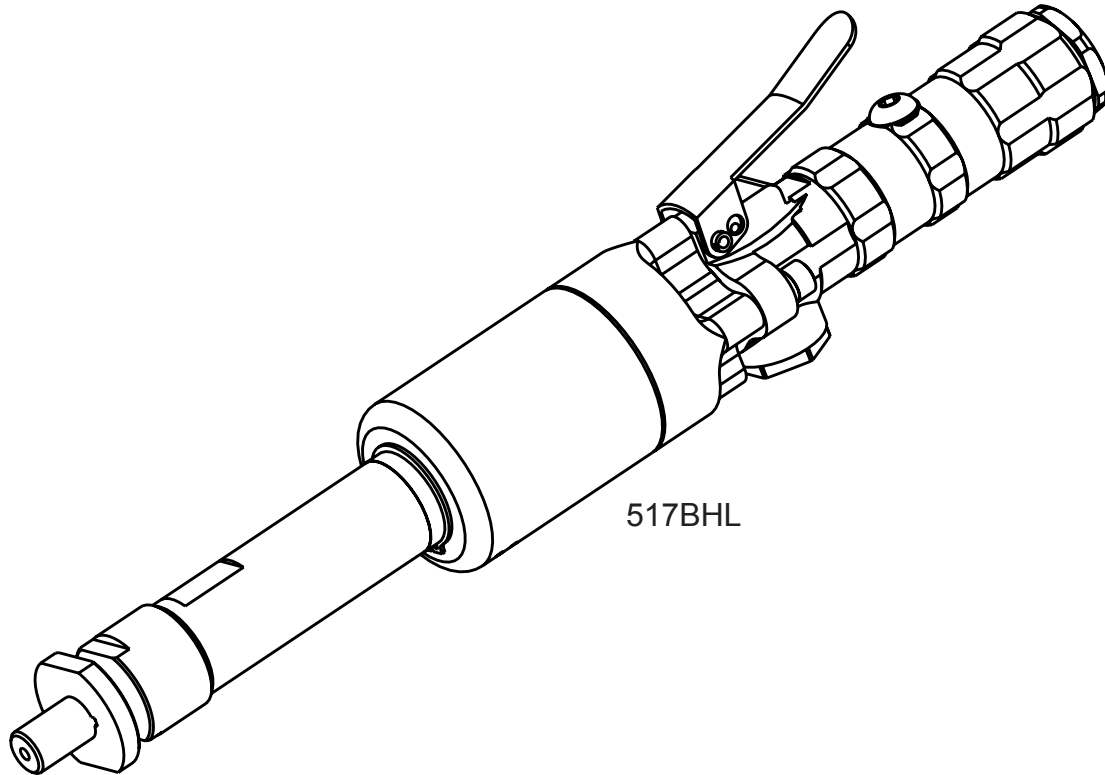

## General Operators Instructions and Maintenance Manual

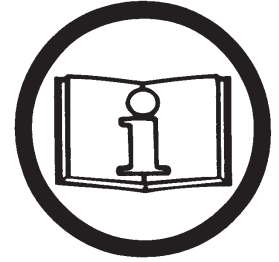

Read Safety Recommendations Before Operating Tool

### 517BH Series Horizontal Cone Grinders

Model Number	Exhaust Direction	Throttle Type	Rated Speed	Power Output	Case Material	Weight		Overall Length	Body Diameter	Working Air Consumption	Spindle Length & Thread
						Aluminum	Steel				
517BHL	(F) Front or Side	(L) Lever or (K) Safety Lever	6000 - 15000 R.P.M.	1.5 H.P (1130 W)	(S) Steel or Aluminum	5.9 Lb. (2.7 Kg)	7.2 Lb. (3.3 Kg)	17.7 Inch (450mm)	2.5 Inch (63.5 mm)	35 cfm (16.5 L/s)	5/8-11 X 0.9 Inch (5/8-11 X 23 mm)
517BHK											
517BHB											
517BIBM											
517BHG						6.9 Lb. (3.1 Kg)	8.2 Lb. (3.7 Kg)				

#### Capacity

- Any Type 16, 17, 17R, 18 or 18R Cone Wheels w/ 5/8-11 Mounting (2 inch maximum)

**Top Cat ® Air Tools, Manufactured by T.C. Service Co.**

38285 Pelton Road, Willoughby, OH 44094 U.S.A.

Ph: (440) 954-7500 or (800) 321-6876 • Fax: (440) 954-7118 or (877) 800-3589

E-Mail: sales@tcservice.com • Web Site: www.tcservice.com

# Operators Instructions and Safety Precautions

This is meant to highlight sections of safety standards published by the American National Standards Institute and the Occupational Safety and Health Administration. This is not meant to replace those standards but only highlight certain areas.

When care is taken to ensure that the right tool is operated properly, and safety and maintenance procedures are followed, accidents can be avoided. Read and follow all instructions and directions. Comply with all rules governing the use of power tools, personal protective equipment and equipment guards.

Remember - machines, attachments and accessories must be used only for the purpose for which they were designed. Safety reasons and product liability prohibit any modifications to tools. Any attachments or accessories must be agreed to in advance with an authorized technical representative of T.C. Service Co.



The grinding equipment must be approved for the rated speed of the machine. The rated speed, marked on the machine, should not be exceeded. Be sure to learn the proper handling and storage of abrasive wheels and inserted tooling.

Inspect the wheel guard for any signs of wear and that it is properly mounted to the tool. Any guard showing signs of wear such as bends, chips, nicks, or cracks should be replaced.



Check hose size and air pressure. The air pressure at the tool shall not exceed 90 psi (6.2 bar). All hoses should be inspected regularly and kept away from heat, oil and sharp edges. Be sure the tool is secured to the air hose.

Measure the speed of grinders every 20 hours of actual use or once per week, whichever comes first.

Tachometers must be checked and calibrated on a regular basis according to the manufacturers recommendations

Measure speed of all types of grinders after maintenance or repair, whenever a grinder is issued from the tool crib and at each wheel change. Several readings should be taken.

This form of inspection should be made with the grinding wheel or tooling removed.



Always wear eye and hearing protection, and when necessary, other personal protective equipment such as gloves, an apron, and helmet. Properly fitted protective clothing cushion the operator from vibration exposure and help prevent minor scrapes that might occur as a result of guiding the tool along the work piece.

Additional information on eye protection is available in the following national regulatory standards.

- 1) Federal OSHA Regulations 29 CFR, Section 1910.133 (Eye and Face Protection)
- 2) ANSI Z87.1 (Occupational and Educational Eye and Face Protection)



Proper mounting of grinding wheels and inserted tooling is crucial to safe operation and efficient working conditions. Ensure the exhaust air is directed away from bystanders.



Airborne particulate resulting from the grinding process can cause hazards. Wear appropriate protective equipment.



Disconnect the tool from the air supply before doing any service. This prevents accidental start-ups. Do not disassemble or adjust the governor. The governor is guaranteed for the life of the tool, if not abused.

## Safety in Operation

The safety procedures for operating air tools are everyone's responsibility. The following lists several aspects of air tool safety that should be considered during operation. Please be aware of these aspects and report any unsafe practice you see to a supervisor or safety officer immediately.

- 1) Start any new cone wheel under a bench and away from bystanders. (Run for a minimum of one minute.)
- 2) When starting a cold/new wheel, apply to the work slowly, allowing the wheel to warm gradually.
- 3) Support the work piece properly.
- 4) When cutting off, support the work piece so that a jamming of the wheel does not occur. (A Slot shall remain constant or become wider during operation.)
- 5) If a jamming of the wheel does occur during a cutting off operation, shut the air supply off to the tool and ease the wheel free. (Inspect the wheel for damage before continuing operation.)
- 6) Ensure that sparks from the process do not create a hazard to the eyes or will ignite the environment.
- 7) Grinders shall not be used in potentially explosive atmospheres.
- 8) Pneumatically driven tools are not generally insulated from coming in contact with electrical sources. Be sure to avoid contact with wires or other possible current carrying sources.
- 9) The operator must check that no bystanders are in the vicinity.
- 10) Remember that there is a running on after the throttle has been released.
- 11) If a grinder fitted with an abrasive wheel is dropped, the wheel must be thoroughly examined before re-use.
- 12) Disconnect the tool from the air source before servicing and changing wheels.
- 13) Release the control device in case of interruption of air supply.
- 14) Always keep the tool in a clean, dry place when not in use.
- 15) Beware of loose hair and clothing so as not to become tangled or trapped during operation.
- 16) Unexpected tool movement or breakage of wheel tooling may cause injury.
- 17) Unsuitable postures may not allow counteracting of normal or unexpected movement of a power tool. (A working position shall be adopted which remains stable in the event of a break up of the wheel.)
- 18) Do not hold the tool near the body when operating.
- 19) Keep a firm grip on the tool body during operation.
- 20) Immediately shut off the tool if unusual vibration or sound is detected. Remove and inspect the wheel and check the tool speed (RPM) with an accurate tachometer. Use of over-speeding grinder or unbalanced wheels may result in serious injury.

# Maintenance

## 517BH

AA-500-90: 9000  
 AA-500-120: 12000  
 AA-500-150: 15000  
 OTHER SPEEDS AVAILABLE

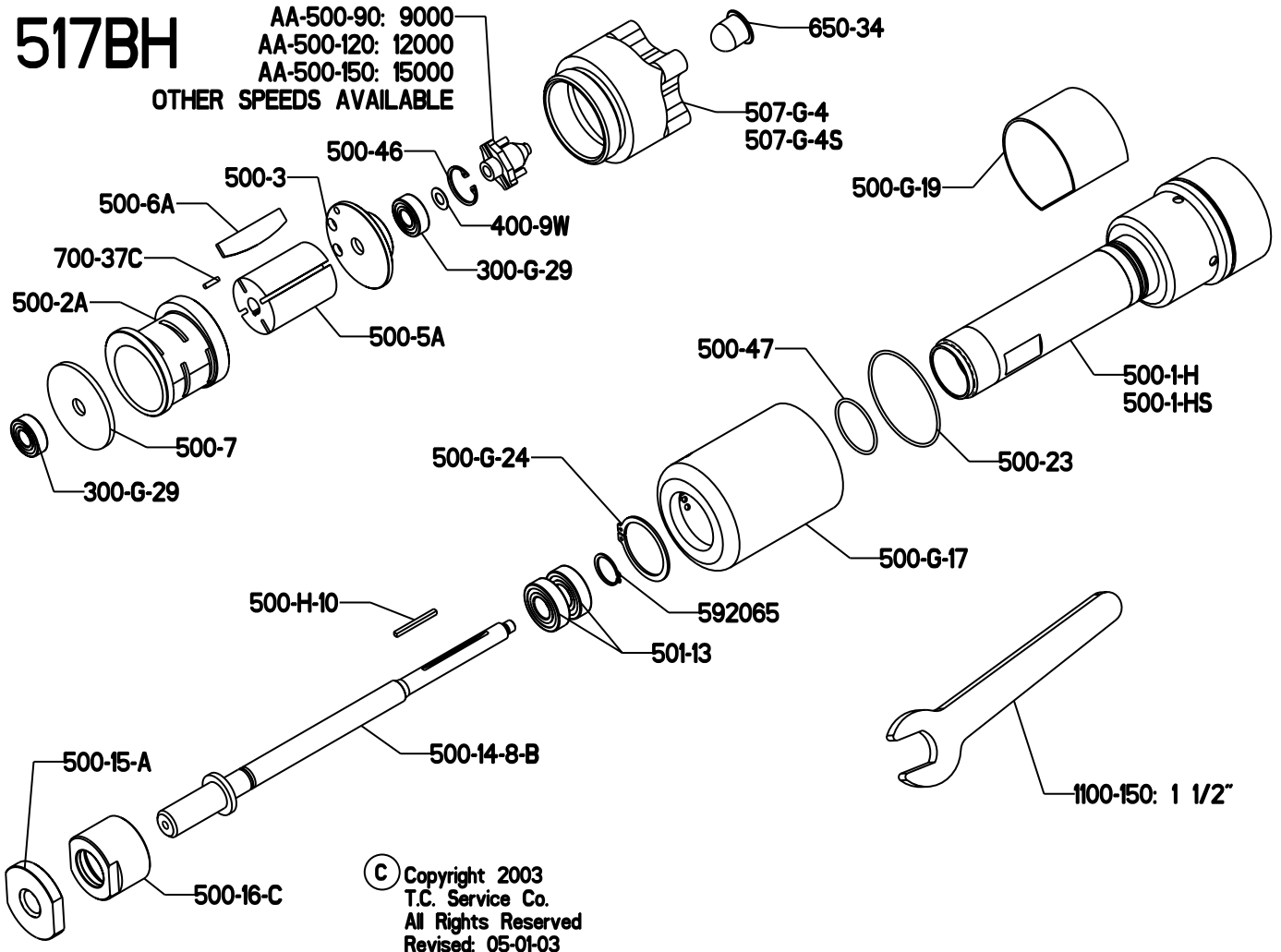

© Copyright 2003  
 T.C. Service Co.  
 All Rights Reserved  
 Revised: 05-01-03

### Disassembly

1. Disconnect air and remove all wheels and accessories.
2. Secure tool in vise vertically with output of tool oriented toward upward direction. Clamp onto the sides of the live handle (do not to clamp on lever).
3. Unscrew motor housing (500-H-1[S]) (right hand thread) from back-head (507-G-4[S]) using flats on housing. Remove handle assembly from vise.
4. Clamp tool assembly into vise vertically with the output out tool oriented toward the downward direction. Clamp onto the flats of the front drive flange (500-15-A).
5. Unscrew and remove governor assembly (AA-500-XX) (**Left hand thread**). Remove spacer (400-9W) from end of spindle (500-14-8). Remove from vise.
6. Remove snap ring (500-46) from groove in rear endplate (500-3).
7. Rap sharply on the rear O.D. of the motor housing with a plastic hammer. The rear end plate, cylinder (500-2A) and blades (500-6A) will dislodge and can be easily removed.
8. Move rotor (500-5A) back and fourth until it slides over the key (500-H-10). Remove rotor and key.
9. Rap rear O.D. of housing and the front endplate (500-7) will slide out.
10. Re-install key and slide spindle holder (1100-820) over the key. Make sure the holder goes all the way down into the case. Clamp holder in vise vertically and remove front flange (500-15A) (right hand thread).
11. Remove from vise. Remove spindle holder and key.
12. Secure the housing assembly in vise vertically with output of tool oriented toward downward direction. Clamp on flats of bearing cap (500-16C) in center of vise.
13. Loosen and unscrew housing (left hand thread). Remove from vise.
14. Secure the housing assembly in vise vertically with output of tool oriented toward downward direction.

Clamp on neck of housing in center of vise.

15. Use a 3/16 inch punch to drive the spindle through the center bearing (300-G-29). Remove from vise.
16. Remove the center bearing from case by tapping the bearing toward the back of the tool with long driver.
17. Remove snap ring (592065) from spindle with snap ring pliers.
18. Support the spindle assembly on a suitable drill block. Press the spindle through the double front bearings.
19. Remove snap ring (500-G-24) from spindle with snap ring pliers.
20. Slide exhaust deflector (500-G-17-S) off of housing. Remove o-rings (500-47 and 500-23).
21. To check throttle valve, unscrew plug (700-S-26) and lift out valve spring (600-51) and plunger (560-13). Replace o-ring (200-9) if cracked or worn.

### Assembly

1. All parts should be clean and free of any abrasives.
2. Install o-rings (500-47 and 500-23) on housing (500-1-H[S]). Lightly oil inside of exhaust deflector (500-G-17-S) and slide over case. Install snap ring (500-G-24).
3. Support the double front bearings (501-13) on a suitable drill block. Press the spindle (500-14-8A) through the bearings up to shoulder with an arbor press.
4. Install snap ring (592065) into groove on spindle.
5. Secure the housing assembly in a vise vertically with the output of tool oriented toward the downward direction. Clamp onto the neck of the housing.
6. Place rear bearing (300-G-29) on spindle. Press bearing until it bottoms on shoulder in housing with bearing driver (1100-816).
7. Screw on front cap (500-16-C) (left hand thread) and clamp in center of vise. Tighten down housing with flats provided.
8. Slide front end plate (500-7) over the spindle and into the housing. Remove from vise.
9. Place key (500-H-10) in key slot and slide on spindle holder (1100-820). Secure spindle holder in vise and tighten flange (500-15A). Do not over tighten. Remove spindle holder, but not the key.
10. Slide rotor (500-5A) over key.
11. Install cylinder (500-2A) with locating pin towards rear of tool.
12. Drop in 4 blades (500-6A).
13. Install rear end plate (500-3).

- Be sure to align small locating hole with cylinder pin.
14. Secure flange nut in vise and drive bearing (300-G-29) onto the spindle. Install snap ring (500-46).
  15. Clamp tool assembly into vise vertically with the output out tool oriented toward the downward direction. Clamp onto the flats of the front drive flange (500-15-A).
  16. Slip spacer (400-9W) over end of spindle (500-14-8). Screw on and tighten governor assembly (AA-500-XX) (**Left hand thread**). Remove from vise.

17. Clamp live handle (650-1-AL) and back-head assembly in vise.

16. Place a few drops of oil into the motor assembly and screw onto the back-head.
17. Place wrench on the housing flats (500-1-HS). Run tool and tighten firmly.

18. Reinstall all safety devices and accessories

19. **Check RPM with a reliable tachometer. Tool must run at or below speed stamped on tool.**

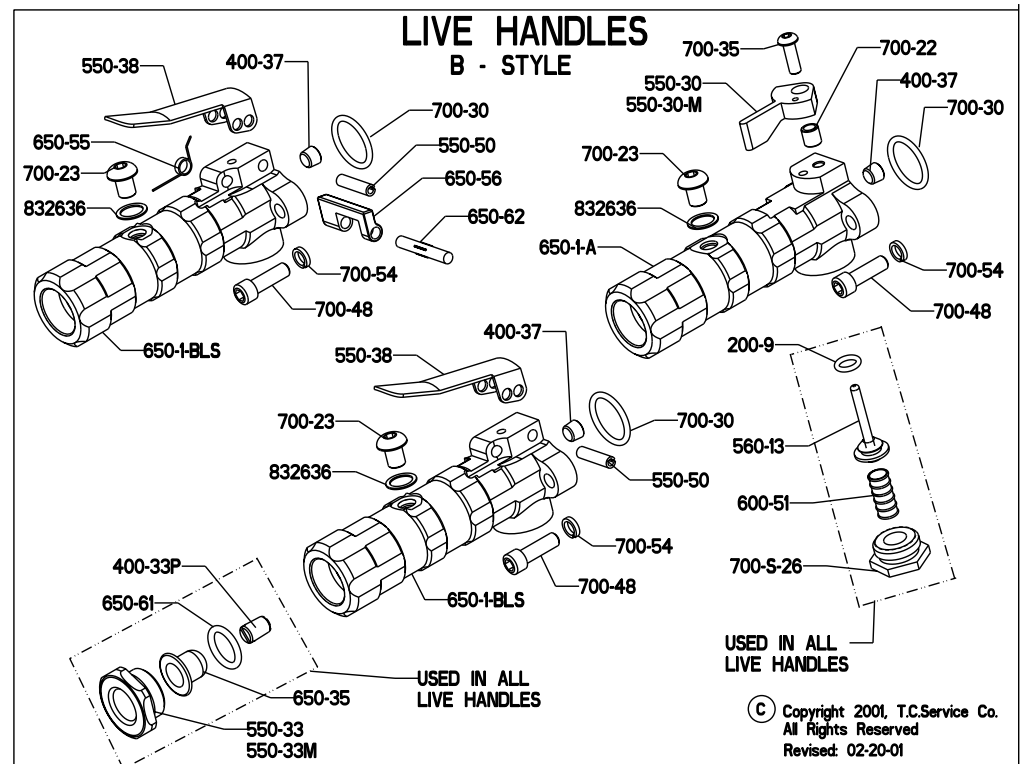

# Tool Parts Listing

<u>PART</u>	<u>DESCRIPTION</u>
300-G-29	BEARING (2 REQ)
400-9W	SPACER
500-G-17-S	EXHAUST DEFLECTOR
500-G-19	MUFFLER
500-G-24	LOCK RING
500-H-10	KEY
500-1-H	ALUMINUM CASE
500-1-HS	STEEL CASE (SPECIFY SPEED)
500-2A	CYLINDER
500-2-C	CHROME CYLINDER
500-3	REAR ENDPLATE
500-5A	ROTOR
500-6A	BLADE (4 REQ)
500-7	FRONT ENDPLATE
500-14-8A	5/8-11 CONE WHEEL SPINDLE
500-15A	WHEEL FLANGE
500-16-C	CAP
500-23	O-RING
500-46	LOCK RING
500-47	O-RING
501-13	BEARING PAIR
507-G-4	ALUMINUM BACKHEAD (SPECIFY SPEED)
507-G-4-S	STEEL BACKHEAD
650-34	SCREEN
700-37C	ROLL PIN
592065	SNAP RING

**Note: Use of any parts other than genuine Top Cat® parts voids any and all warranties, and may result in a hazardous situation and a decrease in operating efficiency.**

## Governors

**The governors are warranted for the life of the tool. (Except in cases of abuse)**

**Please return the governor to the manufacturer for warranty repair or replacement.**

## GOVERNORS

<u>PART</u>	<u>DESCRIPTION</u>
AA-500-70	7000 R.P.M. GOVERNOR
AA-500-90	9000 R.P.M. GOVERNOR
AA-500-120	12000 R.P.M. GOVERNOR
AA-500-150	15000 R.P.M. GOVERNOR

## OTHER SPEEDS AVAILABLE

## TOOLS

<u>PART</u>	<u>DESCRIPTION</u>
1100-150	1-1/2" WRENCH
1100-816	300-G-29 BEARING DRIVER
1100-820	SPINDLE HOLDER

## ASSEMBLIES

<u>PART</u>	<u>DESCRIPTION</u>
510110	REPAIR KIT

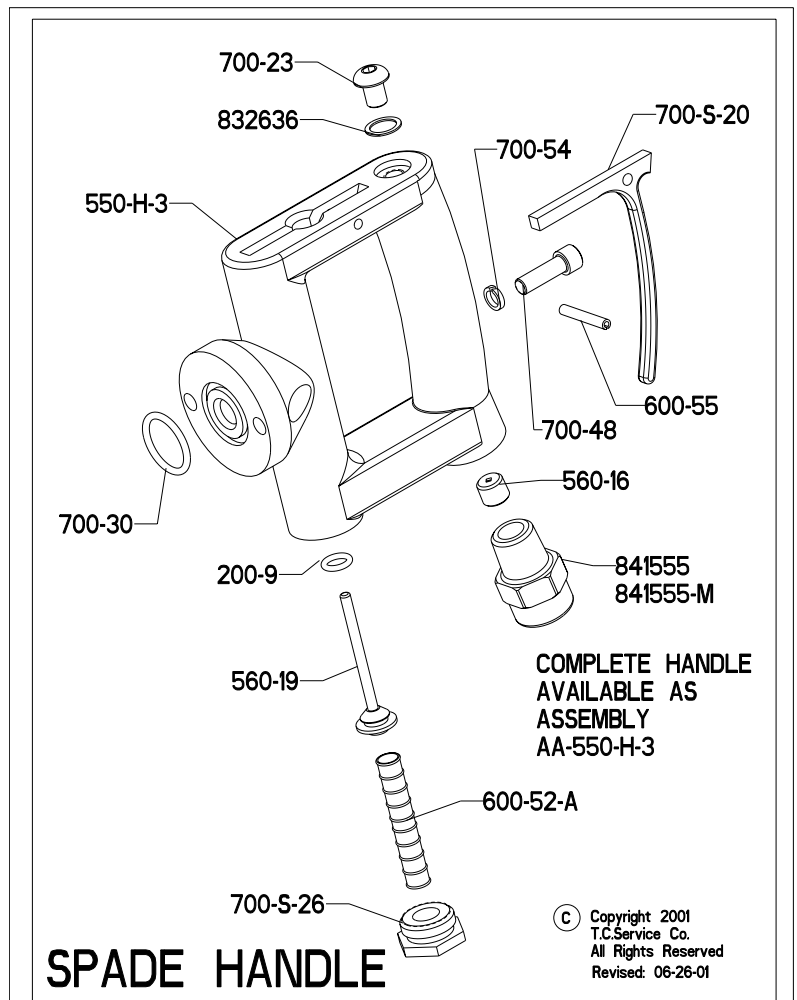

**SPADE HANDLE**

# Live Handle Parts Listing

<u>PART NUMBER</u>	<u>DESCRIPTION</u>	<u>HANDLE ASSEMBLIES</u>	
		<u>PART NUMBER</u>	<u>DESCRIPTION</u>
200-9	THROTTLE VALVE O-RING		
400-33P	OILER PLUG		
400-37	SET SCREW		
550-30	OPERATING BUTTON		
550-30M	MACHINE MOUNT BUTTON		
550-33	ADAPTER CAP		
550-33M	METRIC ADAPTER CAP		
550-38	LEVER	AA-650-1A	BUTTON HANDLE ASSY.
550-50	LEVER PIN	AA-650-1-AM	MACHINE MOUNT HANDLE ASSY.
560-13	THROTTLE VALVE ASSY (INCLUDES 200-9)		
600-51	THROTTLE VALVE SPRING		
650-1A	BARE BUTTON HANDLE	AA-650-1-BL	LEVER HANDLE ASSY.
650-1AT	BARE TURNED DOWN BUTTON HANDLE	AA-650-1-BLS	SAFETY HANDLE ASSY.
650-1B-KN	BARE KNURLED BUTTON HANDLE	AA-650-1 BL-KN	KNURLED LEVER HANDLE ASSY.
650-1-BLS	BARE LEVER HANDLE		
650-1-BLS-KN	BARE KNURLED SAFETY HANDLE	AA-650-1-BL-KN-W	KNURLED LEVER HANDLE ASSY. W/ WRAP
650-1-U	BARE PINNED LEVER HANDLE	AA-650-1-UK	PINNED/SAFETY LEVER HANDLE ASSY
650-35	SCREEN BASKET		
650-55	SAFETY LOCKOUT SPRING	AA-650-1-UL	PINNED LEVER HANDLE ASSY
650-56	LOCKOUT		
650-61	O-RING		
650-62	SAFETY LEVER LOCKOUT PIN		
700-22	SPACER FOR BUTTON HANDLES		
700-23	OILER PLUG SCREW		
700-30	O-RING		
700-35	BUTTON HANDLE SCREW		
700-48	SCREW (2 REQ.)		
700-54	LOCK WASHER (2 REQ.)		
700-S-26	THROTTLE VALVE CAP		
832636	GASKET		

# Spade Handle Parts Listing

<u>PART NUMBER</u>	<u>DESCRIPTION</u>
200-9	THROTTLE VALVE O-RING
550-H-3	BARE SPADE HANDLE HOUSING
560-16	SET SCREW
560-19	THROTTLE VALVE (INCLUDES O-RING 200-9)
600-52A	THROTTLE VALVE SPRING
600-55	TRIGGER PIN
700-23	SCREW
700-30	O-RING
700-48	SCREW (2 REQ.)
700-54	LOCK WASHER (2 REQ.)
700-S-20	TRIGGER
700-S-26	THROTTLE VALVE CAP
832636	GASKET
841553	1/2 INCH NPT X 1/2 INCH NPT SCREEN HANDLE BUSHING
841553-M	1/2 INCH NPT X 1/2 INCH BSP SCREEN HANDLE BUSHING

<u>HANDLE ASSEMBLIES</u>	
<u>PART NUMBER</u>	<u>DESCRIPTION</u>
AA-550-H-3	SPADE HANDLE ASSY.

# Ergonomics - Work Healthy

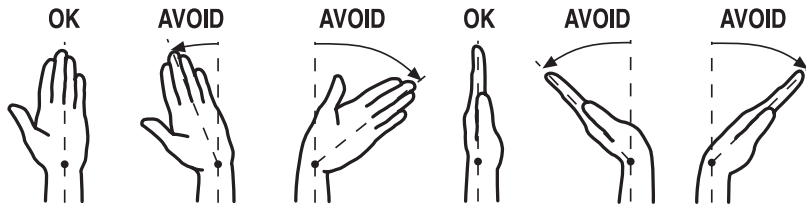

The following suggestions will help reduce or moderate the effects of repetitive work motion and/or extended vibration exposure:

- 1) Do not over-grip the machine/tool. Use only the force required to maintain control.
- 2) Keep hands and body dry and warm. (Blood flow is important - exercise hands and arms as often as necessary.)
- 3) Keep wrists as straight as possible. (Avoid hand positions that require the wrist to be flexed, hyper extended or turned side-to-side.)
- 4) Avoid anything that may inhibit blood circulation such as smoking tobacco or cold temperatures.
- 5) Do not support body-weight on the tool during operation.
- 6) Maintain a stress-free posture for the entire body.

Prolonged exposure to vibrations created by vibrating sources may cause health hazards. There are gloves, handle wraps and other forms of protective measures available to help reduce the hazard. The fit and condition of any vibration abatement measure must be monitored.

## Installation and Maintenance Tips

Following the guidelines will help you to ensure the pneumatic tools your company uses are operating and are maintained in the very best of condition.

### Initial Inspection of a New Tool

When a new tool is delivered to your facility, it is important to inspect the tool for any signs of damage that may have occurred during shipping. Here is a list of things to inspect:

- With the tool disconnected from the air supply, depress the throttle lever or trigger. The device should move freely and not become caught.
- Inspect the guard of the tool, if so equipped. The guard should be free of any chips, nicks or dents.
- Inspect the spindle of the tool. The threads should show no signs of bends or chips. Grasp the spindle by hand and spin. The spindle should turn freely with no resistance.

### Plumbing Installation

The tool must have fittings and connectors installed into the air inlet in order to connect with your companies air system. Your choice of fittings can greatly affect the performance of the tool.

### Fitting Size

The size of the air inlet of the tool is the minimum size of fitting that will allow for proper airflow into the tool. Should a smaller fitting size be used such as reducers or adapters, this will constrict the airflow into the tool and reduce the overall performance.

### Coupling Size and Installation

The coupling size should be equal to or larger than the inlet size of the tool. If a smaller size coupling is used then the air supply volume may be reduced which may lead to reduced performance from the tool. The coupling should be installed near to the tool. It is important that the tool receive internal lubrication on a regular basis. Having the connection closer to the tool will promote regular lubrication, as the connection is easily accessible. Hose whips are often used between the tool and the coupling.

Use thread sealant on all pipe threads and ensure a tight fit.

### Operating Speed Test

After your initial inspection and installation of the plumbing connections, it is important to test for the operating speed of the tool. This test should be performed before you install any abrasive or tooling. Each tool is stamped with a maximum operating speed. This speed determines the highest rotational speed in R.P.M.'s that the tool will turn when it is functioning properly. This speed was set from the factory and is closely related to the operating speed of the abrasive used with the tool. This relationship will be discussed in the "mounting abrasives" section.

Find the maximum operating speed stamped onto the tool. Connect the tool to an air supply that provides 90 psi and secure the tool in a vise. A lower or higher air pressure will result in a false speed test and may create a hazardous situation. Depress the throttle lever or trigger and run the tool. Use a properly calibrated tachometer to determine the actual operating speed of the tool. The actual operating speed on the tachometer should be no more than 95% of the maximum free speed stamped on the tool. If this is not the case then contact the distributor or tool manufacturer immediately. The tool must not be put into service if the actual speed is over 95% of the stamped maximum speed.

Example: Tool rated at 6000 R.P.M.

$$90\% \text{ of } 6000 \text{ } (.90 \times 6000) = 5400$$

$$95\% \text{ of } 6000 \text{ } (.95 \times 6000) = 5700$$

The tool should run between 5400 and 5700 R.P.M.'s when tested with a tachometer. The tool should run between 5400 and 5700 when tested with a tachometer. Tachometers must be checked and calibrated on a regular basis according to the manufacturers recommendations

### Mounting Abrasives

The mounting of the abrasive used with the tool is very important to ensure safety for the operator and proper functioning of the tool. There are strict rules for mounting wheels that are outlined in ANSI B7.1-2000. The following diagrams briefly describe the methods and equipment for mounting most abrasives.

Each wheel/mounted stone is labeled with a maximum operating speed. It is extremely important to compare this rating with the maximum operating speed of the tool. Never mount a wheel on a tool where the maximum operating speed of the tool is higher than the maximum operating speed of the wheel. This can cause an over speed situation and can result in injury.

The following list details specific items one should inspect and be aware of when mounting abrasives.

- The maximum operating speed marked on the wheel must be equal to or higher than the rated spindle speed (free speed) of the tool.
- Check the wheel dimensions so that it fits within the guard properly.
- Do not use any wheel that shows cracks, chips or evidence it has been soaked in fluids.
- Wheel flanges should have flat contact surfaces and be without cracks or burrs.
- Immediately shut off the tool if unusual sound or vibration is detected. Remove and inspect the wheel and check the tool speed (RPM). Use of over-speeding grinder or unbalanced wheels may result in serious injury.

### Testing the Mounted Wheel

Start any new grinder with a new wheel under a bench and away from any bystanders. Run at full speed for one minute.

### Ensure Proper Pressure, Filtration & Lubrication

Properly lubricated pneumatic tools work better, last longer between maintenance intervals and are safer in

## HORIZONTAL TOOL FOR USE WITH CONE WHEELS

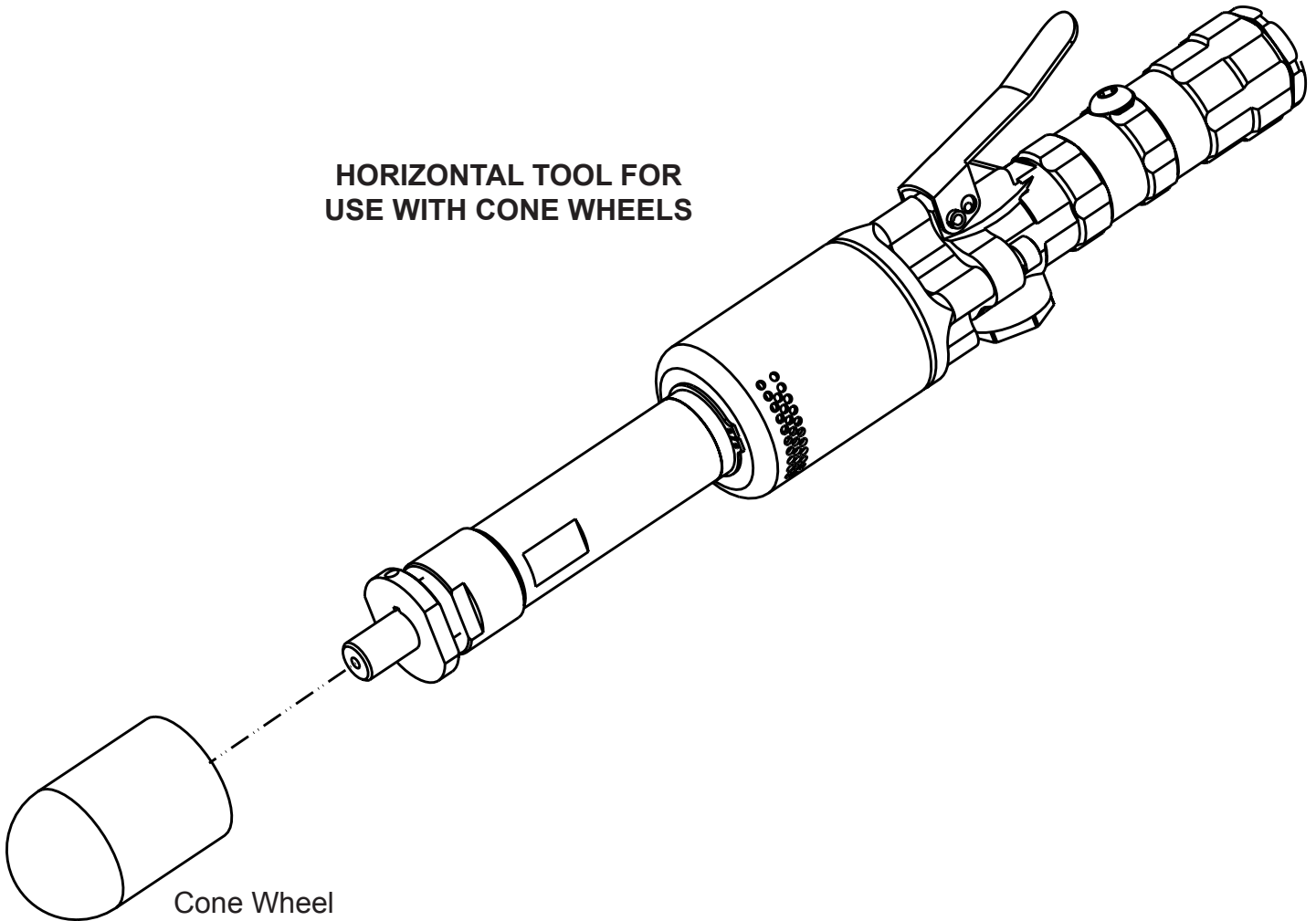

general use. The maintenance costs are reduced dramatically when a little time is taken to regularly lubricate the tools. There are several ways to ensure proper lubrication.

### 1) Filters, Regulators & Lubricators

These devices should be installed in the air system at each grinding station and inspected regularly to ensure proper operation. Each device in this set performs a vital task that greatly affects the performance of the tool and overall longevity of the component parts.

#### **Filters**

A filter is a device used to trap/contain particulate and liquid contaminants in the compressed air system. They generally have a cartridge or screen that requires cleaning or replacement regularly. Without this maintenance, the filtering device can become clogged and reduce the flow of air to the tool. A loss in performance can result.

#### **Regulators**

A regulator adjusts the operating pressure supplied to the tool. This device generally is used with a pressure gauge that will indicate the current pressure setting. All Top Cat ® pneumatic tools are designed to operate at 90 PSI (6.2 bar) while the tool is running. The tool should never be run if the pressure should exceed 90 PSI (6.2 bar).

#### **Lubricators**

Lubricators are devices that induce a controlled amount of oil into the air supply for pneumatically driven tools. They generally contain a reservoir that one must keep filled with oil. A light grade oil such as Mobil DTE light or equivalent is recommended. There is a variable setting on the lubricator that will determine the amount of oil induced into the air supply. It is important to inspect both the setting and amount of oil in the lubricator regularly to determine proper functioning of the device. The lack of oil in the air system will greatly reduce the performance and longevity of the pneumatically driven tool.

### 2) Direct injection of oil into the tool

A simple and easy way to ensure proper lubrication is to inject the oil directly into the tool air inlet. This should be performed prior to storage of the tool. To perform this task one must have a small container of the proper lubricating oil.

- Disconnect the tool from the air supply at the air coupling.
- Place a few drops of oil from the container into the air inlet of the tool directly.
- Reconnect the tool to the air supply.
- Direct the exhaust of the tool away from any bystanders or cover the exhaust with a shop rag.
- Run the tool until the oil has completely passed through the unit.

The best lubrication techniques include both methods.

### What Conditions Indicate the Need for Maintenance?

Pneumatic tools will exhibit several distinct signs that maintenance is required. Higher costs can be avoided if maintenance is performed when the first signs are evident. The following list details conditions that may indicate the necessity for service.

- 1) With the tool disconnected from the air supply, grasp the spindle and spin in the direction of operation. The spindle should spin freely with no resistance.
- 2) With the tool disconnected from the air supply, grasp the spindle by hand. Attempt to move the spindle from side to side and back and forth. Excess play can be a sign that service is required.
- 3) A reduction in power may indicate the necessity for maintenance.
- 4) Should the tool not maintain a uniform operating speed, servicing may be required.

### Parts & Maintenance Program

The wearing of any particular part in a tool can be caused by many different factors. It is impossible to predict the wear from all the factors that can occur in the general work environment. The following is to serve as a general guideline of wear considered normal from the repetitive use of the tool. The following components comprise the major wear items of the 517 series pneumatic grinder. Each part has different wear characteristics that will be explained in detail. Components that are not listed here are also capable of experiencing wear. Replacement of these parts is considered on an "As Needed" basis.

#### The Common Wear Items

The Blades (500-6A) are subjected to contaminants within the air system. It is common for grit or sand to enter the tool through the air system and become lodged onto the blades. This can cause the blades to delaminate where pieces of blade material will flake off. Any blade exhibiting this characteristic should be replaced. The blades will see the most wear on the longest edge along their height. This is the surface that makes contact with the cylinder wall and creates an air seal. The overall width of the blade will reduce as this surface wears. When any one-end width of the blade wears to the minimum width, (.220 INCH) then one should consider replacement.



The Bearings (300-G-29 and 501-13). There is no means of measurement that can determine the condition of a bearing. The only test that can be performed is so manually turn either the outer or inner race with respect to each other. The movement should feel free with no resistance. If resistance is felt either continuous or repetitive, then the bearing should be replaced.

The Front Endplate (500-7). The front endplate is a flat steel disc in the front of the motor assembly. The rotor makes occasional contact with the front endplate. Over time, this contact will wear away the surface of the endplate and result in a circular depression in the middle of the part. When this depression becomes 0.003 inches deep from the original surface, then the efficiency of the motor is reduced to the point where one should replace the endplate.

Note – The front endplates are designed so either front or back surface can be used toward the motor. When one side is judged as unusable, the part can be flipped during reassembly and new wear surface is available.

The Rotor (500-5). We employ a floating rotor design in the majority of our motors. This design allows the rotor to float along the spindle in the motor cavity. Occasionally the rotor will make contact with the endplates. Some wear can be seen on both the top and bottom surfaces of the overall length. Should the overall length wear to the minimum length of 1.742 inches then the rotor should be replaced.

The Cylinder (500-2A). The only wear seen on the cylinder is going to occur on the inner surface. This surface is always in contact with the blades. Over time, the blades will remove material from this surface that will reduce the overall performance of the tool. Consecutive high and low spots will become evident on the internal surface. They will appear as ridges along the axis of the cylinder. When these ridges vary 0.016 inches from high to low, the cylinder should be replaced.

The Rear Endplate (500-3). The rear endplate is the located toward the rear of the motor assembly. The most wear this part is exposed to is from occasional contact with the rotor. Over time, this contact will wear away the surface of the endplate and result in a circular depression in the middle of the part. When this depression becomes 0.003 inches deep from the original surface, then the efficiency of the motor is reduced to the point where one should replace the endplate.

This covers all of the predictable wear that can occur within the tool. Other factors due to environment, level of treatment/care and air supply quality can cause other forms of wear that are unpredictable

### **For More Information**

1) General Industry Safety & Health Regulations 29 CFR, Part 1910 and where applicable Construction Industry Safety & Health Regulations 29 CFR, Part 1926 available from Superintendent of Documents, Gov't. Printing Office, Washington, D.C. 20402.

2) Safety Code For Portable Air Tools, ANSI B186.1, B7.1 and Z87.1, available from American National Standards Institute, Inc. 1430 Broadway, New York, NY 10018

## **Grinders**

- Vertical Grinders
- Horizontal Grinders
- Right Angle Grinders
- Die Grinders
- Extended Grinders
- Bench Grinders

## **Saws**

## **Drills**

## **Percussion Tools**

- Scalers
- Needle Scalers
- Chipping Hammers
- Rammers

## **Polishers**

- Vertical Polishers
- Horizontal Polishers
- Right Angle Polishers

## **Air Motors**



T.C. Service Co.  
38285 Pelton Rd.  
Willoughby, OH 44094  
U.S.A.  
Ph: 440-954-7500  
Fax: 440-954-7118

© Copyright 2004  
All Rights Reserved