

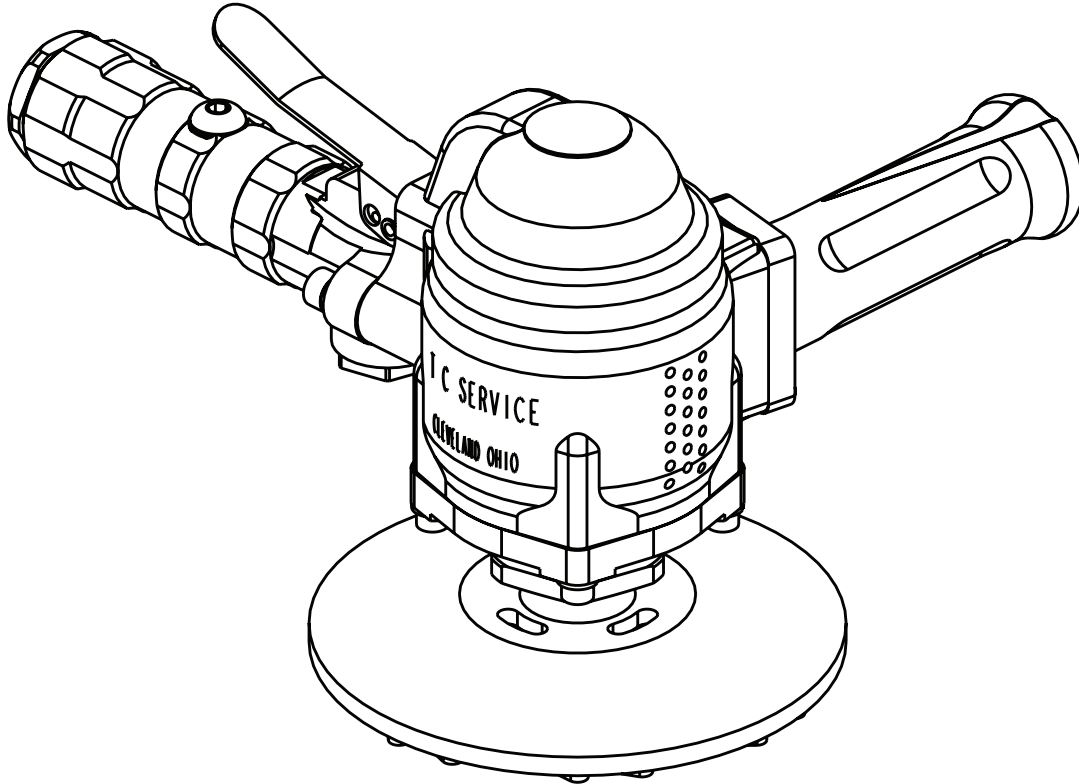

### General Operators Instructions and Maintenance Manual

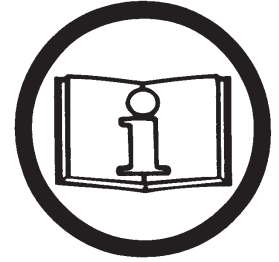

Read Safety Recommendations Before Operating Tool

#### 56S Series Vertical Sanders

Model Number	Throttle Type	Power Output	Weight	Height Over Spindle	Working Air Consumption	Rated Speed/Sanding Pad Capacity
56SL	Lever	3 H.P. (2250 W)	8.8 Lbs. (4.0 Kg)	7.1 Inches (180 mm)	45 cfm (21.2 L/s)	<ul style="list-style-type: none"> <li>• 6000 - 7SP : 6000 RPM w/ 7 Inch Sanding Pad</li> <li>• 6000 - 9SP : 6000 RPM w/ 9 Inch Sanding Pad</li> <li>• 8000 - 7SP : 8000 RPM w/ 7 Inch Sanding Pad</li> </ul>
56SK	Safety Lever					
56SB	Button Switch					

**Top Cat ® Air Tools, Manufactured by T.C. Service Co.**

38285 Pelton Road, Willoughby, OH 44094 U.S.A.

Ph: (440) 954-7500 or (800) 321-6876 • Fax: (440) 954-7118 or (877) 800-3589

E-Mail: [sales@tcservice.com](mailto:sales@tcservice.com) • Web Site: [www.tcservice.com](http://www.tcservice.com)

# Operators Instructions and Safety Precautions

This is meant to highlight sections of safety standards published by the American National Standards Institute and the Occupational Safety and Health Administration. This is not meant to replace those standards but only highlight certain areas.

When care is taken to ensure that the right tool is operated properly, and safety and maintenance procedures are followed, accidents can be avoided. Read and follow all instructions and directions. Comply with all rules governing the use of power tools, personal protective equipment and equipment guards.

Remember - machines, attachments and accessories must be used only for the purpose for which they were designed. Safety reasons and product liability prohibit any modifications to tools. Any attachments or accessories must be agreed to in advance with an authorized technical representative of T.C. Service Co.



The grinding equipment must be approved for the rated speed of the machine. The rated speed, marked on the machine, should not be exceeded. Be sure to learn the proper handling and storage of abrasive wheels and inserted tooling.

Inspect the wheel guard for any signs of wear and that it is properly mounted to the tool. Any guard showing signs of wear such as bends, chips, nicks, or cracks should be replaced.



Always wear eye and hearing protection, and when necessary, other personal protective equipment such as gloves, an apron, and helmet.



Airborne particulate resulting from the grinding process can cause hazards. Wear appropriate protective equipment.

Check hose size and air pressure. The air pressure at the tool shall not exceed 90 psi (6.2 bar). All hoses should be inspected regularly and kept away from heat, oil and sharp edges. Be sure the tool is secured to the air hose.



Measure the speed of grinders every 20 hours of actual use or once per week, whichever comes first.

Measure speed of all types of grinders after maintenance or repair, whenever a grinder is issued from the tool crib and at each wheel change. Several readings should be taken.

This form of inspection should be made with the grinding wheel or tooling removed.

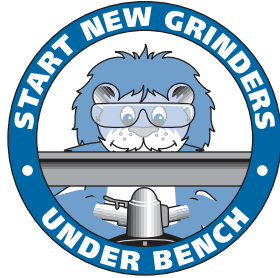

Proper mounting of grinding wheels and inserted tooling is crucial to safe operation and efficient working conditions. Ensure the exhaust air is directed away from bystanders.



Disconnect the tool from the air supply before doing any service. This prevents accidental start-ups. Do not disassemble or adjust the governor. The governor is guaranteed for the life of the tool, if not abused.

## Safety in Operation

The safety procedures for operating air tools are everyone's responsibility. The following lists several aspects of air tool safety that should be considered during operation. Please be aware of these aspects and report any unsafe practice you see to a supervisor or safety officer immediately.

- 1) Start any new wheel under a bench and away from bystanders. (Run for a minimum of one minute.)
- 2) When starting a cold/new wheel, apply to the work slowly, allowing the wheel to warm gradually.
- 3) Support the work piece properly.
- 4) When cutting off, support the work piece so that a jamming of the wheel does not occur. (A Slot shall remain constant or become wider during operation.)
- 5) If a jamming of the wheel does occur during a cutting off operation, shut the air supply off to the tool and ease the wheel free. (Inspect the wheel for damage before continuing operation.)
- 6) Ensure that sparks from the process do not create a hazard to the eyes or will ignite the environment.
- 7) Grinders shall not be used in potentially explosive atmospheres.
- 8) Pneumatically driven tools are not generally insulated from coming in contact with electrical sources. Be sure to avoid contact with wires or other possible current carrying sources.
- 9) The operator must check that no bystanders are in the vicinity.
- 10) Remember that there is a running on after the throttle has been released.
- 11) If a grinder fitted with an abrasive wheel is dropped, the wheel must be thoroughly examined before re-use.
- 12) Disconnect the tool from the air source before servicing and changing wheels.
- 13) Release the control device in case of interruption of air supply.
- 14) Always keep the tool in a clean, dry place when not in use.
- 15) Beware of loose hair and clothing so as not to become tangled or trapped during operation.
- 16) Unexpected tool movement or breakage of inserted tooling may cause injuries to lower limbs.
- 17) Unsuitable postures may not allow counteracting of normal or unexpected movement of a power tool. (A working position shall be adopted which remains stable in the event of a break up of inserted tooling.)
- 18) Do not hold the tool near the body when operating.
- 19) Keep a firm grip on the tool body during operation.

# Maintenance

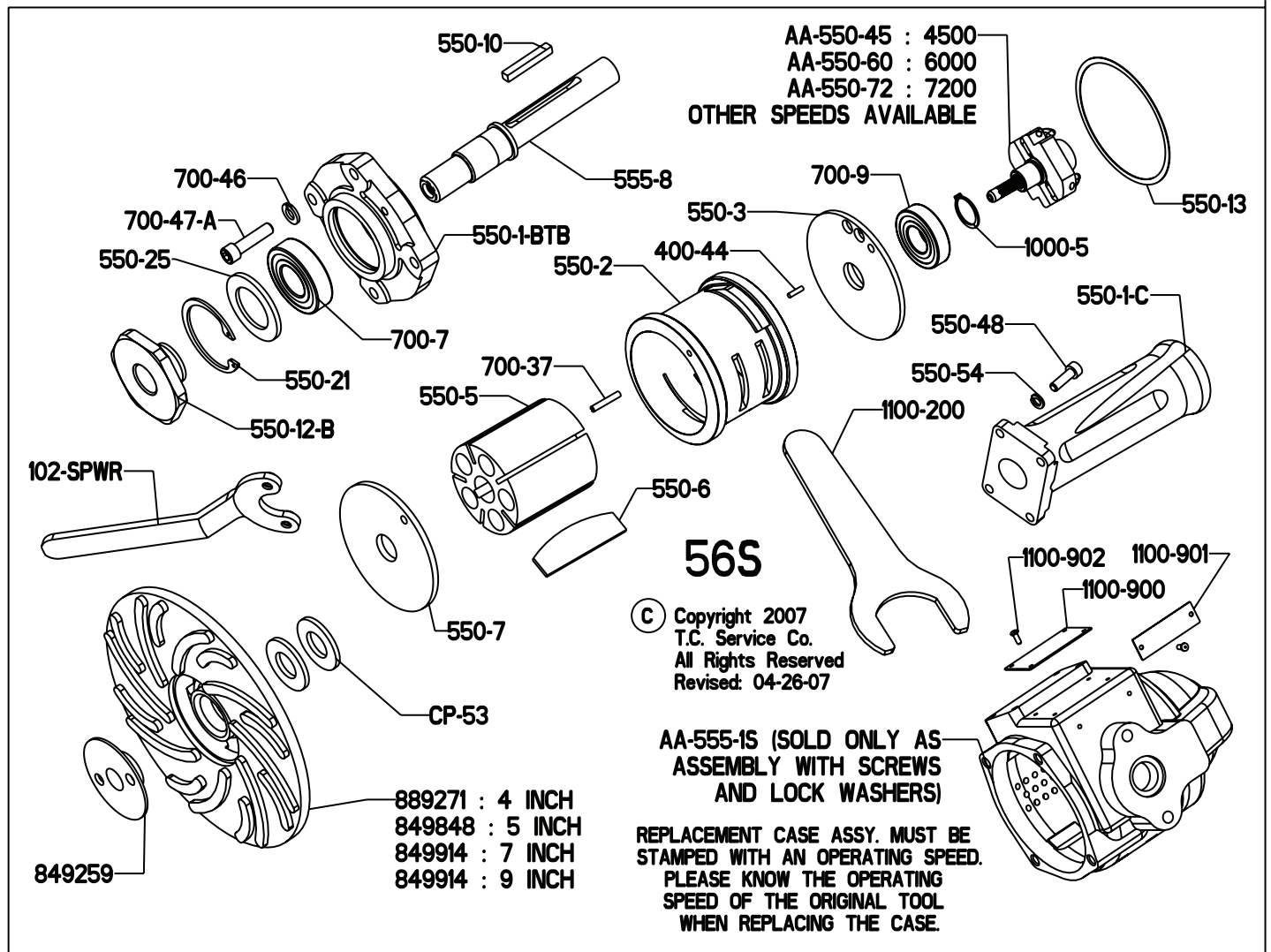

## Disassemble

1. Disconnect tool from air supply and remove all wheels and accessories.
2. Secure tool in a vise with motor axis in horizontal position. Clap onto the dead handle (550-1C) of grinder.
3. Remove four screws (700-47A), four lock washers (700-46) and wheel guard (700-200, 700-201 or 412988).
4. Grasp motor output and pull complete motor assembly from case. The motor assembly must be kept straight to pull from case easily. Try to maintain alignment as best as possible. Remove case from vise.
5. Secure motor assembly into vise vertically with governor toward upward direction. Clamp onto flats of wheel flange (550-12B).
6. Remove governor (AA-550-XX) with use of governor wrench (1100-825). (Left-hand thread)
7. Remove lock ring (1000-5) with use of snap ring pliers. Remove from vise.
8. Hold motor assembly by the cylinder in one hand. Place a punch in the hole left by the removal of governor. Tap lightly onto the punch with small hammer. This will drive the spindle (550-8) through the rear bearing (700-9) and rear endplate (550-3). (Take care not to damage threads inside spindle, or to drop the spindle assembly when it becomes free.)
9. Use a small screwdriver to push the rear bearing out of the rear endplate.
10. Remove the cylinder (550-2), the rotor blades (550-6) and the rotor (550-5). Leave the key (550-10) in the key slot for now.
11. Clamp spindle holder (1100-650) into vise vertically. Align key slot in holder with key of spindle and slide spindle assembly through.
12. Remove wheel flange (550-12B). Remove from vise.
13. Remove key (550-10) and lift off front end plate (550-7).
14. Support front bearing assembly on a suitable drill block. Press spindle (550-8) through front bearing (700-7) with arbor press.
15. Remove snap ring (550-21) with use of snap ring pliers.
16. Lift out bearing cover (550-25).
17. Press out front bearing (700-7) from front bearing support (550-1-BTB).
18. To check throttle valve, unscrew throttle valve cap (700-S-26). Lift out valve spring (600-51) and throttle valve (560-13). Replace o-ring (200-9) if cracked or torn.



# Tool Parts Listing

## PART NUMBER

400-44 CYLINDER PIN  
 550-1-BTB BEARING SUPPORT  
 550-1-C DEAD HANDLE  
 550-1-C-H HOLLOWED DEAD HANDLE  
 550-1-C-KN KNURLED DEAD HANDLE  
 550-1-C-KN-W DEAD HANDLE WRAP  
 550-2 CYLINDER  
 550-2C CHROME CYLINDER  
 550-3 REAR ENDPLATE  
 550-3C CHROME REAR ENDPLATE  
 550-5 ROTOR  
 550-5A ALUMINUM ROTOR  
 550-6 BLADE (5 REQ.)  
 550-7 FRONT ENDPLATE  
 550-7C CHROME FRONT ENDPLATE  
 555-8 SPINDLE  
 550-10 KEY  
 550-12B WHEEL FLANGE  
 550-13 GASKET  
 550-21 SNAP RING  
 550-25 BEARING COVER  
 550-48 SCREW (4 REQ.)  
 550-54 WASHER (4 REQ.)  
 550-86 TYPE 28 GUARD EXTENDER  
 550-87 NUT  
 600-48 GOV. PIN RETAINER  
 650-58 SCREW  
 650-59 WASHER  
 700-7 BEARING  
 700-9 BEARING  
 700-34 SPINDLE NUT  
 700-37 CYLINDER PIN  
 700-46 WASHER (4-8 REQ.)  
 700-47A SCREW (4 REQ.)  
 1000-5 LOCK RING

## **TOOLS**

### PART NUMBER

1100-200  
 1100-650  
 1100-808  
 1100-825  
 1100-834  
 102-SPWR  
 541228

### DESCRIPTION

2" WRENCH  
 SPINDLE HOLDER  
 700-9 BEARING DRIVER  
 GOVERNOR WRENCH  
 700-7 BEARING DRIVER  
 SANDING PAD NUT WRENCH  
 2" X 12" LONG WRENCH

## **ASSEMBLIES**

### PART NUMBER

510071  
 AA-650-1A  
 AA-650-1-AM  
 AA-650-1-BL  
 AA-650-1-BLS  
 AA-650-1 BL-KN  
 AA-650-1-BL-KN-W  
 AA-650-1-UK  
 AA-650-1-UL  
 AA-555-1S  
 AA-555-1S-PA

### DESCRIPTION

REPAIR KIT  
 BUTTON HANDLE ASSY.  
 MACHINE MOUNT HANDLE ASSY.  
 LEVER HANDLE ASSY.  
 SAFETY HANDLE ASSY.  
 KNURLED LEVER HANDLE ASSY.  
 KNURLED LEVER HANDLE ASSY.  
 W/ WRAP  
 PINNED/SAFETY LEVER HANDLE ASSY.  
 PINNED LEVER HANDLE ASSY.  
 CASE ASSY. (SPECIFY SPEED)  
 PIPED AWAY EXHAUST CASE ASSY. (SPECIFY SPEED)

## **GOVERNORS**

### PART NUMBER

AA-550-30  
 AA-550-45  
 AA-550-60  
 AA-550-80

### DESCRIPTION

GOV.ASSY. (3000 RPM)  
 GOV.ASSY. (4500 RPM)  
 GOV.ASSY. (6000 RPM)  
 GOV.ASSY. (8000 RPM)

- OTHER SPEEDS AVAILABLE
- ALWAYS USE SAME OR LOWER SPEED GOVERNOR AS IS STAMPED ON CASE

## **ACCESSORIES**

### PART NUMBER

849259  
 889271  
 849848  
 849848-R  
 849850  
 849913  
 849914

### DESCRIPTION

5/8-11 SANDING PAD NUT  
 5/8-11 4" SANDING PAD (MAX 12000 RPM)  
 5/8-11 5" SANDING PAD (MAX 10000 RPM)  
 5/8-11 5" RIGID SANDING PAD (MAX 10000 RPM)  
 5/8-11 6" SANDING PAD (MAX 8500 RPM)  
 5/8-11 7" SANDING PAD (MAX 8500 RPM)  
 5/8-11 9" SANDING PAD (MAX 6500 RPM)

# Handle Parts Listing

<u>PART NUMBER</u>	<u>DESCRIPTION</u>
200-9	THROTTLE VALVE O-RING
400-33P	OILER PLUG
400-37	SET SCREW
550-30	OPERATING BUTTON
550-30M	MACHINE MOUNT BUTTON
550-33	ADAPTER CAP
550-33M	METRIC ADAPTER CAP
550-38	LEVER
550-50	LEVER PIN
560-13	THROTTLE VALVE ASSY (INCLUDES 200-9)
600-51	THROTTLE VALVE SPRING
650-1A	BARE BUTTON HANDLE
650-1AT	BARE TURNED DOWN BUTTON HANDLE
650-1B-KN	BARE KNURLED BUTTON HANDLE
650-1-BLS	BARE LEVER HANDLE
650-1-BLS-KN	BARE KNURLED SAFETY HANDLE
650-1-U	BARE PINNED LEVER HANDLE
650-35	SCREEN BASKET
650-55	SAFETY LOCKOUT SPRING
650-56	LOCKOUT
650-61	O-RING
650-62	SAFETY LEVER LOCKOUT PIN
700-22	SPACER FOR BUTTON HANDLES
700-23	OILER PLUG SCREW
700-30	O-RING
700-35	BUTTON HANDLE SCREW
700-48	SCREW (2 REQ.)
700-54	LOCK WASHER (2 REQ.)
700-S-26	THROTTLE VALVE CAP
832636	GASKET

## **HANDLE ASSEMBLIES**

<u>PART NUMBER</u>	<u>DESCRIPTION</u>
AA-650-1A	BUTTON HANDLE ASSY.
AA-650-1-AM	MACHINE MOUNT HANDLE ASSY.
AA-650-1-BL	LEVER HANDLE ASSY.
AA-650-1-BLS	SAFETY HANDLE ASSY.
AA-650-1 BL-KN	KNURLED LEVER HANDLE ASSY.
AA-650-1-BL-KN-W	KNURLED LEVER HANDLE ASSY. W/ WRAP
AA-650-1-UK	PINNED/SAFETY LEVER HANDLE ASSY
AA-650-1-UL	PINNED LEVER HANDLE ASSY

## Ergonomics - Work Healthy

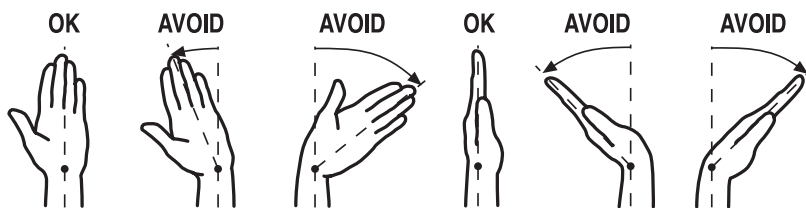

The following suggestions will help reduce or moderate the effects of repetitive work motion and/or extended vibration exposure:

- 1) Do not over-grip the machine/tool. Use only the force required to maintain control.
- 2) Keep hands and body dry and warm. (Blood flow is important - exercise hands and arms as often as necessary.)
- 3) Keep wrists as straight as possible. (Avoid hand positions that require the wrist to be flexed, hyper extended or turned side-to-side.)
- 4) Avoid anything that may inhibit blood circulation such as smoking tobacco or cold temperatures.
- 5) Do not support body-weight on the tool during operation.
- 6) Maintain a stress-free posture for the entire body.

Prolonged exposure to vibrations created by vibrating sources may cause health hazards. There are gloves, handle wraps and other forms of protective measures available to help reduce the hazard. The fit and condition of any vibration abatement measure must be monitored.

# Installation and Maintenance Tips

Following the guidelines will help you to ensure the pneumatic tools your company uses are operating and are maintained in the very best of condition.

## Initial Inspection of a New Tool

When a new tool is delivered to your facility, it is important to inspect the tool for any signs of damage that may have occurred during shipping. Here is a list of things to inspect:

- With the tool disconnected from the air supply, depress the throttle lever or trigger. The device should move freely and not become caught.
- Inspect the guard of the tool, if so equipped. The guard should be free of any chips, nicks or dents.
- Inspect the spindle of the tool. The threads should show no signs of bends or chips. Grasp the spindle by hand and spin. The spindle should turn freely with no resistance.

## Plumbing Installation

The tool must have fittings and connectors installed into the air inlet in order to connect with your company's air system. Your choice of fittings can greatly affect the performance of the tool.

## Fitting Size

The size of the air inlet of the tool is the minimum size of fitting that will allow for proper airflow into the tool. Should a smaller fitting size be used such as reducers or adapters, this will constrict the airflow into the tool and reduce the overall performance.

## Coupling Size and Installation

The coupling size should be equal to or larger than the inlet size of the tool. If a smaller size coupling is used then the air supply volume may be reduced which may lead to reduced performance from the tool.

The coupling should be installed near to the tool. It is important that the tool receive internal lubrication on a regular basis. Having the connection closer to the tool will promote regular lubrication, as the connection is easily accessible. Hose whips are often used between the tool and the coupling. Use thread sealant on all pipe threads and ensure a tight fit.

## Operating Speed Test

After your initial inspection and installation of the plumbing connections, it is important to test for the operating speed of the tool. This test should be performed before you install any abrasive or tooling. Each tool is stamped with a maximum operating speed. This speed determines the highest rotational speed in R.P.M.'s that the tool will turn when it is functioning properly. This speed was set from the factory and is closely related to the operating speed of the abrasive used with the tool. This relationship will be discussed in the "mounting abrasives" section.

Find the maximum operating speed stamped onto the tool. Connect the tool to an air supply that provides 90 psi and secure the tool in a vise. A lower or higher air pressure will result in a false speed test and may create a hazardous situation. Depress the throttle lever or trigger and run the tool. Use a properly calibrated tachometer to determine the actual operating speed of the tool. The actual operating speed on the tachometer should be 90-95% of the maximum free speed stamped on the tool. If this is not the case then contact the distributor or tool manufacturer immediately. The tool must not be put into service if the actual speed is over 95% of the stamped maximum speed.

Example: Tool rated at 6000 R.P.M.

90% of 6000 (.90 x 6000) = 5400

95% of 6000 (.95 x 6000) = 5700

The tool should run between 5400 and 5700 when tested with a tachometer.

### Mounting Abrasives

The mounting of the abrasive used with the tool is very important to ensure safety for the operator and proper functioning of the tool. There are strict rules for mounting wheels that are outlined in ANSI B7.1-2000. The following diagrams briefly describe the methods and equipment for mounting most abrasives.

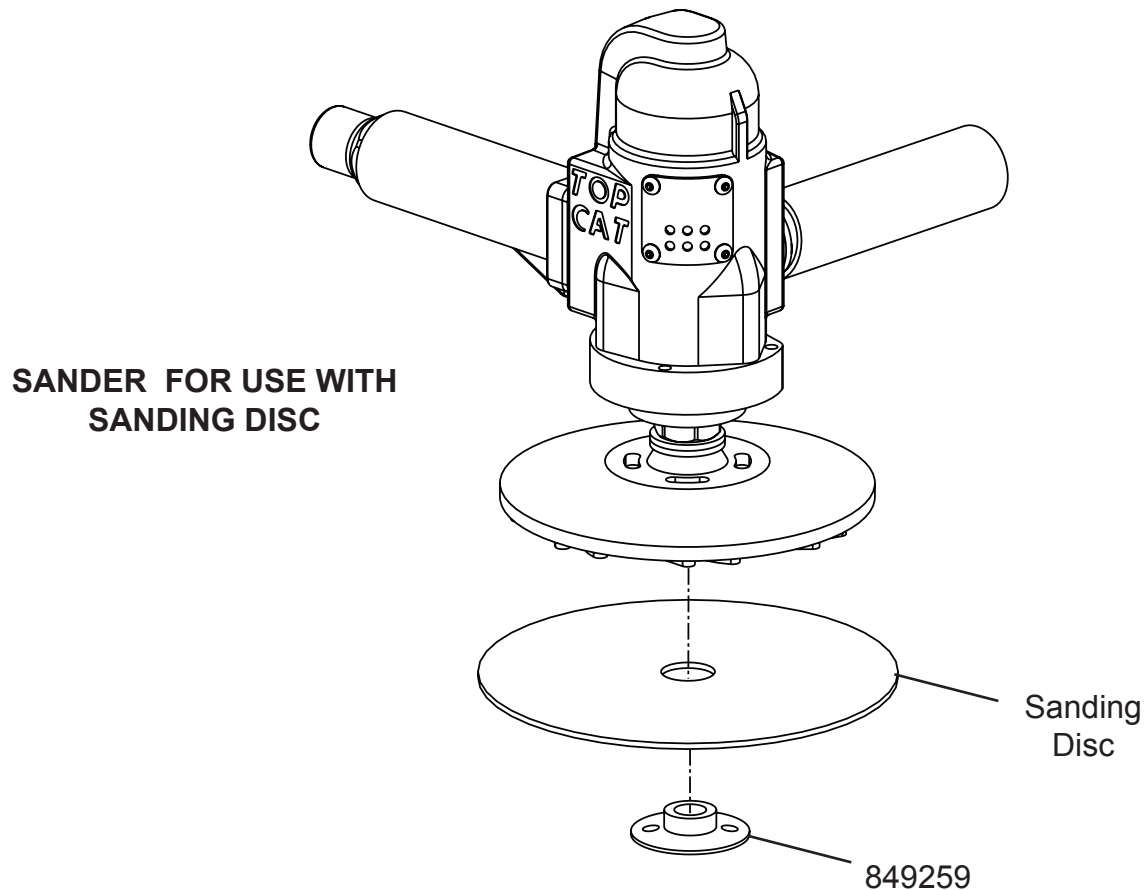

Each wheel is labeled with a maximum operating speed. It is extremely important to compare this rating with the maximum operating speed of the tool. Never mount a wheel on a tool where the maximum operating speed of the tool is higher than the maximum operating speed of the wheel. This can cause an over speed situation and can result in injury.

The following list details specific items one should inspect and be aware of when mounting abrasives.

- The maximum operating speed marked on the wheel must be equal to or higher than the rated spindle speed (free speed) of the tool.
- Check the wheel dimensions so that it fits within the guard properly.
- Do not use any wheel that shows cracks, chips or evidence it has been soaked in fluids.
- Wheel flanges should have flat contact surfaces and be without cracks or burrs.

### Testing and Mounted Wheel

Start any new grinder with a new wheel under a bench and away from any bystanders. Run at full speed for one minute.

### Ensure Proper Pressure, Filtration & Lubrication

Properly lubricated pneumatic tools work better, last longer between maintenance intervals and are safer in general use. The maintenance costs are reduced dramatically when a little time is taken to regularly lubricate the tools. There are several ways to ensure proper lubrication.

#### 1) Filters, Regulators & Lubricators

These devices should be installed in the air system at each grinding station and inspected regularly to ensure proper operation. Each device in this set performs a vital task that greatly affects the performance of the tool and overall longevity of the component parts.

#### **Filters**

A filter is a device used to trap/contain particulate and liquid contaminants in the compressed air system. They generally have a cartridge or screen that requires cleaning or replacement regularly. Without this maintenance, the filtering device can become clogged and reduce the flow of air to the tool. A loss in performance can result.

#### **Regulators**

A regulator adjusts the operating pressure supplied to the tool. This device generally is used with a pressure gauge that will indicate the current pressure setting. All Top Cat ® pneumatic tools are designed to operate at 90 PSI (6.2 bar) while the tool is running. The tool should never be run if the pressure should exceed 90 PSI (6.2 bar).

#### **Lubricators**

Lubricators are devices that induce a controlled amount of oil into the air supply for pneumatically driven tools. They generally contain a reservoir that one must keep filled with oil. A light grade oil such as Mobil DTE light or equivalent is recommended. There is a variable setting on the lubricator that will determine the amount of oil induced into the air supply. It is important to inspect both the setting and amount of oil in the lubricator regularly to determine proper functioning of the device. The lack of oil in the air system will greatly reduce the performance and longevity of the pneumatically driven tool.

## 2) Direct injection of oil into the tool

A simple and easy way to ensure proper lubrication is to inject the oil directly into the tool air inlet. This should be performed prior to storage of the tool. To perform this task one must have a small container of the proper lubricating oil.

- Disconnect the tool from the air supply at the air coupling.
- Place a few drops of oil from the container into the air inlet of the tool directly.
- Reconnect the tool to the air supply.
- Direct the exhaust of the tool away from any bystanders or cover the exhaust with a shop rag.
- Run the tool until the oil has completely passed through the unit.

The best lubrication techniques include both methods.

### What Conditions Indicate the Need for Maintenance?.

Pneumatic tools will exhibit several distinct signs that maintenance is required. Higher costs can be avoided if maintenance is performed when the first signs are evident. The following list details conditions that may indicate the necessity for service.

- 1) With the tool disconnected from the air supply, grasp the spindle and spin in the direction of operation. The spindle should spin freely with no resistance.
- 2) With the tool disconnected from the air supply, grasp the spindle by hand. Attempt to move the spindle from side to side and back and forth. Excess play can be a sign that service is required.
- 3) A reduction in power may indicate the necessity for maintenance.
- 4) Should the tool not maintain a uniform operating speed, servicing may be required.

### **For More Information**

1) General Industry Safety & Health Regulations 29 CFR, Part 1910 and where applicable Construction Industry Safety & Health Regulations 29 CFR, Part 1926 available from Superintendent of Documents, Gov't. Printing Office, Washington, D.C. 20402.

2) Safety Code For Portable Air Tools, ANSI B186.1, B7.1 and Z87.1, available from American National Standards Institute, Inc. 1430 Broadway, New York, NY 10018

### **Grinders**

- Vertical Grinders
- Horizontal Grinders
- Right Angle Grinders
- Die Grinders
- Extended Grinders
- Bench Grinders

### **Polishers**

- Vertical Polishers
- Horizontal Polishers
- Right Angle Polishers

### **Percussion Tools**

- Scalers
- Needle Scalers
- Chipping Hammers
- Rammers

### **Air Motors**

### **Saws**



T.C. Service Co.  
38285 Pelton Rd.  
Willoughby, OH 44094  
U.S.A.  
Ph: 440-954-7500  
Fax: 440-954-7118

© Copyright 2007  
All Rights Reserved