

Chipping Hammers

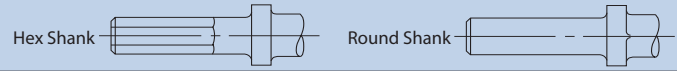

CHIPPING HAMMERS



- Air Inlet Size: 1/4" NPT**
Hose Size Recommendations: 3/8" (10 mm)
Standard Equipment
- Tool • Operating Instructions and Service Manual

The tool for tough working conditions, Top Cat's® chipping hammers are heavy hitters for cleaning castings and light concrete demolition work. (Always use chisel retainer.)

- Hits with more power than a scaler
- Much lighter in weight and size than traditional chipping hammers

Quick Order Number			
Model Number	Handle Style	Tool Nose	Ordering Number
TC183	Lever	Hex	TC-183-L;HEX
		Round	TC-183-L;RND
	Safety Lever	Hex	TC-183-K;HEX
		Round	TC-183-K;RND
	Offset (Pistol)	Hex	TC-183-W;HEX
		Round	TC-183-W;RND

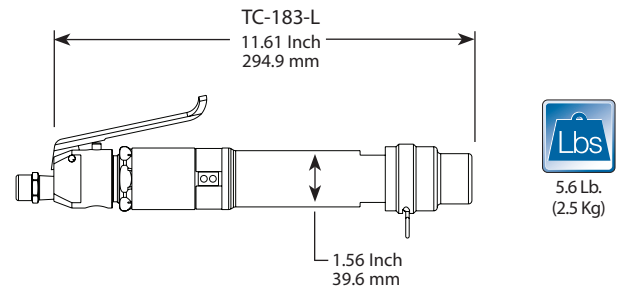

The standard tools come with an oval collar chisel retainer.

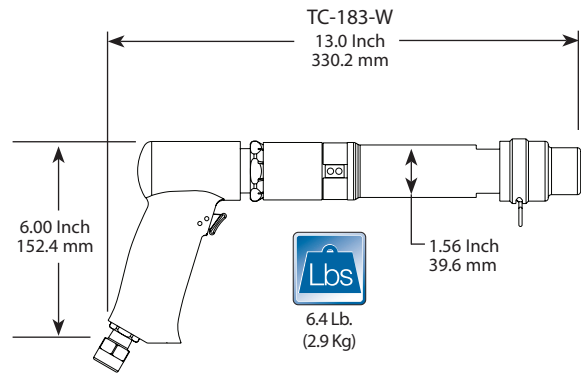

Chisels – 0.580 Hexagon			
Description	Cutting Edge	Overall Length	Part Number
Flat Chisel	1" (25.4mm)	9" (229mm)	839008
Flat Chisel	1" (25.4mm)	12" (305mm)	839009
Flat Chisel	1" (25.4mm)	18" (457mm)	839010
Moil Point		9" (229mm)	839018
Wide Flat	2" (50.8mm)	12" (305mm)	839016

Other Sizes And Styles Available

Chisels – 0.680 Round			
Description	Cutting Edge	Overall Length	Part Number
Flat Chisel	1" (25.4mm)	9" (229mm)	839014
Flat Chisel	1" (25.4mm)	12" (305mm)	839083
Flat Chisel	1" (25.4mm)	18" (457mm)	839045
Moil Point		9" (229mm)	839023
Wide Flat	1.5" (38.1mm)	9" (229mm)	839019
Wide Flat	2" (50.8mm)	9" (229mm)	839017

Other Sizes And Styles Available

cfm
25 cfm (11.8 L/s) Max

stroke
0.94 Inch x 3.0 Inches
(23.9 mm x 76.0 mm)

blow
min.
3500